

“

A BEST IN CLASS,
INNOVATIVE, PRICE
COMPETITIVE AND HIGH
QUALITY PERFORMING
ENGINEERING
ENTERPRISE.

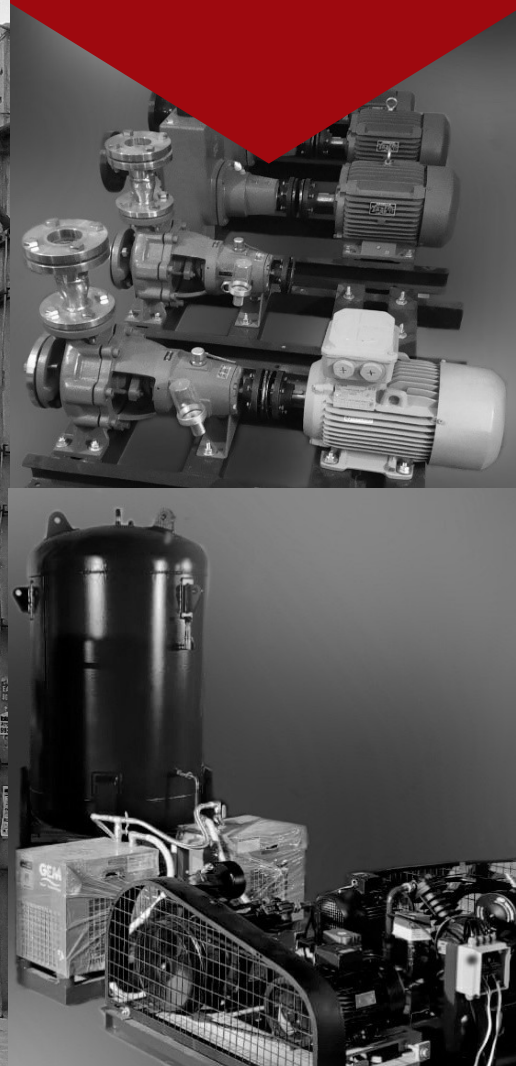

BUCHIYA
CONTROLS PRIVATE
LIMITED
SERVES NEED OF ALL TYPE OF
INDUSTRIES



WATER SYSTEMS

CONTACT US

PLOT NO. 22, MAA KALKA MARG, GURUKUL
INDUSTRIAL AREA,
SECTOR 38, FARIDABAD

Ph.: +91 9891345001; 8851349219

Mail: info.controls@buchiya.com

Visit us at: www.buchiya.com

WATER SYSTEMS BY BCPL



... Serves need of all type of industries

TUBE TYPE HEAT EXCHANGERS

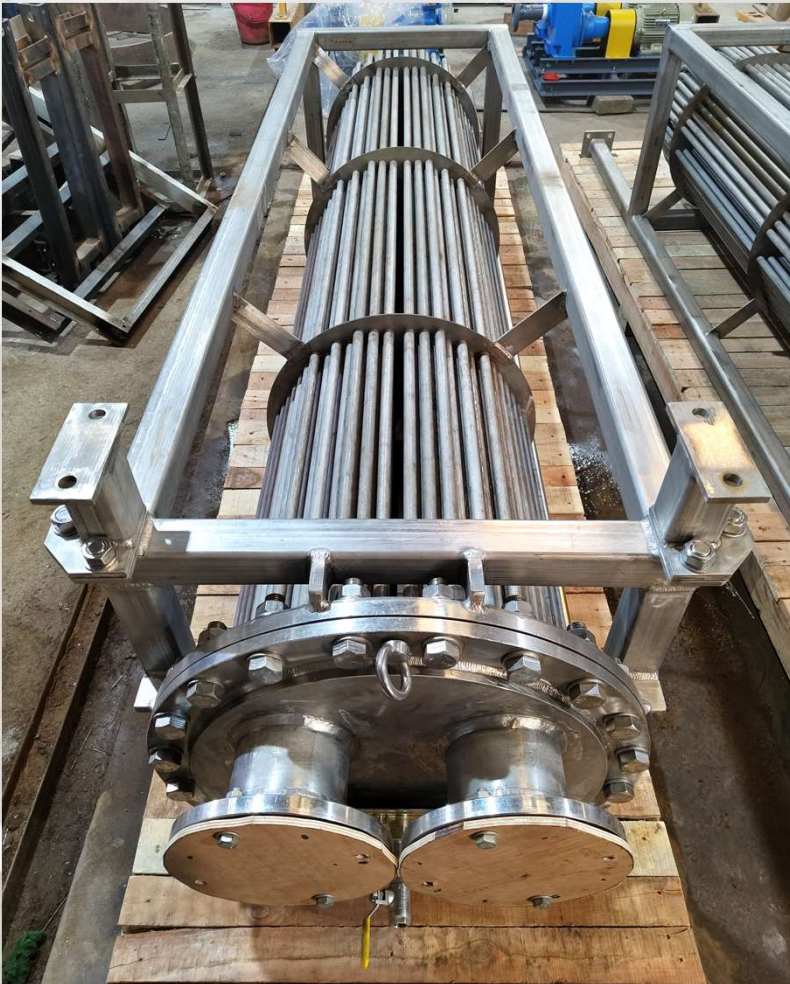

WATER SYSTEMS BY BCPL



Buchiya

... Serves need of all type of industries

JALDHARA, SIKKIM

TUBE TYPE, SIZE-19mm (OD)

HEAT EXCHANGER

Sr.No.	Item	Details
1	FLOW	767 Lpm
2	HEAT LOAD	348.3 KW
4	MOC	SS 316 L

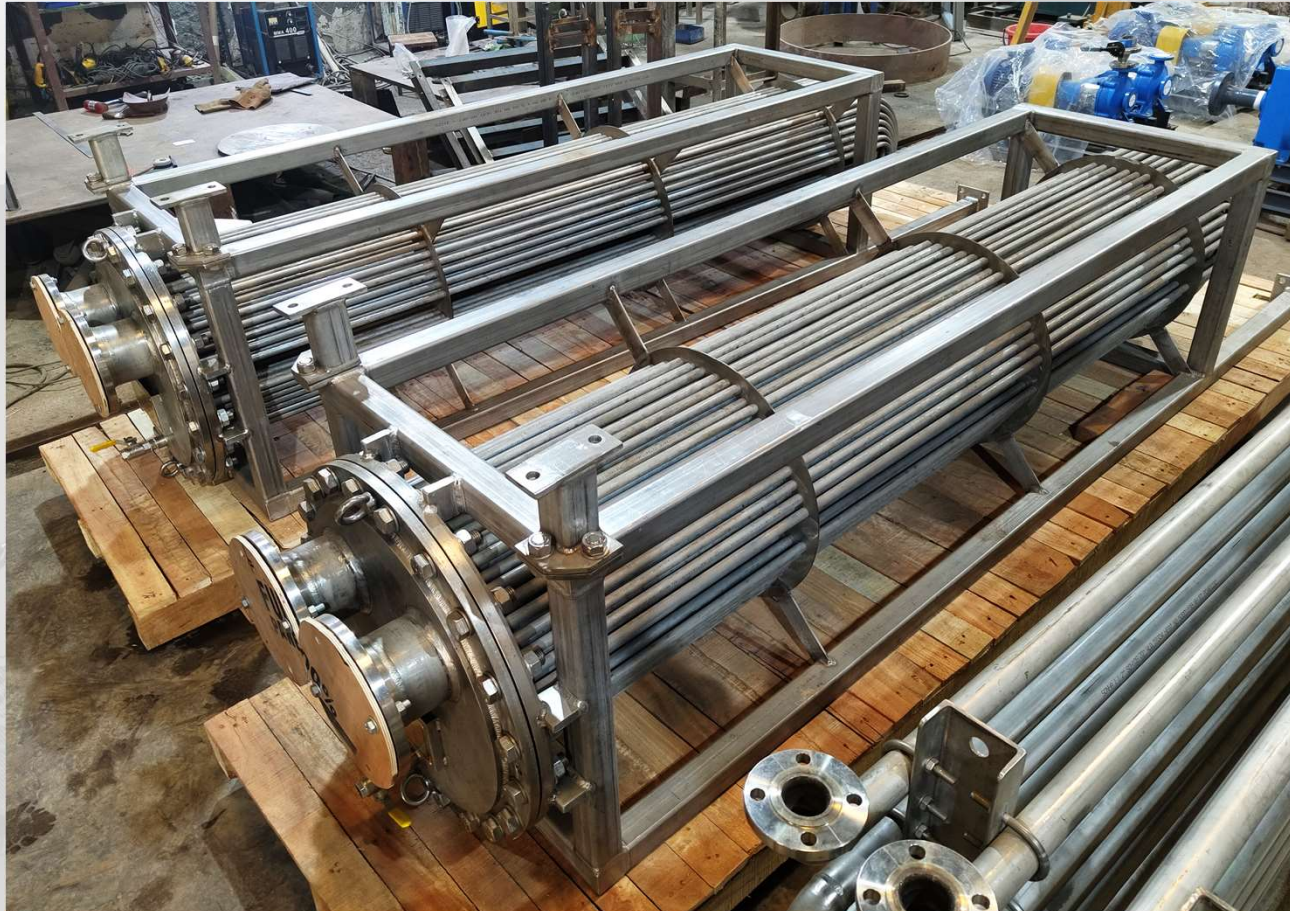

WATER SYSTEMS BY BCPL



Buchiya

... Serves need of all type of industries

LIPING KHOLA (17.9 MW), NEPAL

HEAT EXCHANGER

TUBE TYPE,
SIZE- 25 NB (1")



Sr.No.	Item	Details
1	FLOW	1040 Lpm
2	HEAT LOAD	362.85 KW
4	MOC	SS304



WATER SYSTEMS BY BCPL



Buchiya

... Serves need of all type of industries

KAWARSI (15 MW), HIMACHAL PRADESH

TUBE TYPE, SIZE- 1 1/2" (40NB)

Sr.No.	Item	Details
1	FLOW	115 Lpm
2	HEAT LOAD	56.93 KW
4	MOC	SS304



WATER SYSTEMS BY BCPL



Buchiya

... Serves need of all type of industries

PINNAPURAM (1.2GW), ANDHRA PRADESH

SHAFT SEAL PANEL



Sr. No.	Item	Details
1	FLOW	220 Lpm
2	FILTRATION	50u
3	DESIGN PRESSURE	13 Bar



WATER SYSTEMS BY BCPL



Buchiya

... Serves need of all type of industries

DUPLEX FILTER MULTI & SINGLE CARTRIDGE, SIZE- 15NB TO 400 NB

Sr.No.	Item	Details
1	FLOW	3300 Lpm
2	FILTRATION	100u
3	DESIGN PRESSURE	6 Bar



WATER SYSTEMS BY BCPL



Buchiya

... Serves need of all type of industries



PUMP MOTOR SKIDS

Sr. No.	Item	Details
1	SUBMERSIBLE PUMPS/MOTORS	AS PER REQ.
2	HORIZONTAL PUMPS/MOTORS	AS PER REQ.

DUPLEX FILTERS

Sr. No.	Item	Details
1	DUPLEX FILTERS	15NB - 400NB

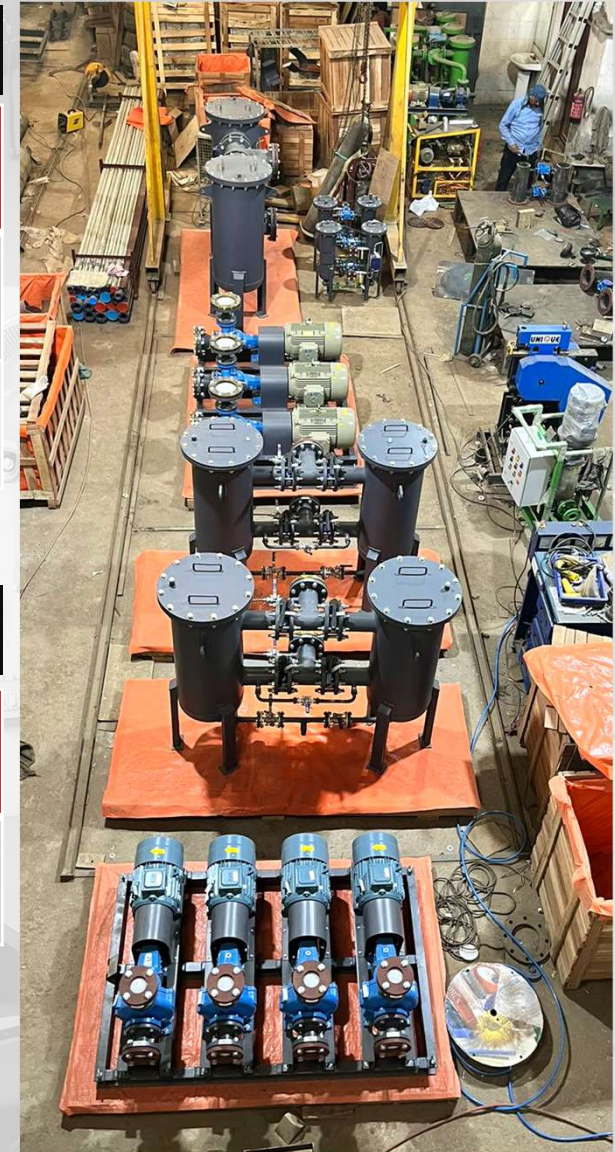

WATER SYSTEMS BY BCPL



Buchiya

... Serves need of all type of industries

KOPILI HEP (200MW), (ASSAM)

AUTO BACKWASH SELF CLEANING FILTER



Sr.No.	Item	Details
1	FLOW	828 m3/hr
2	FILTRATION	2000 μ

3D REPRESENTATION

INLET/
OUTLET
16" (400 NB)

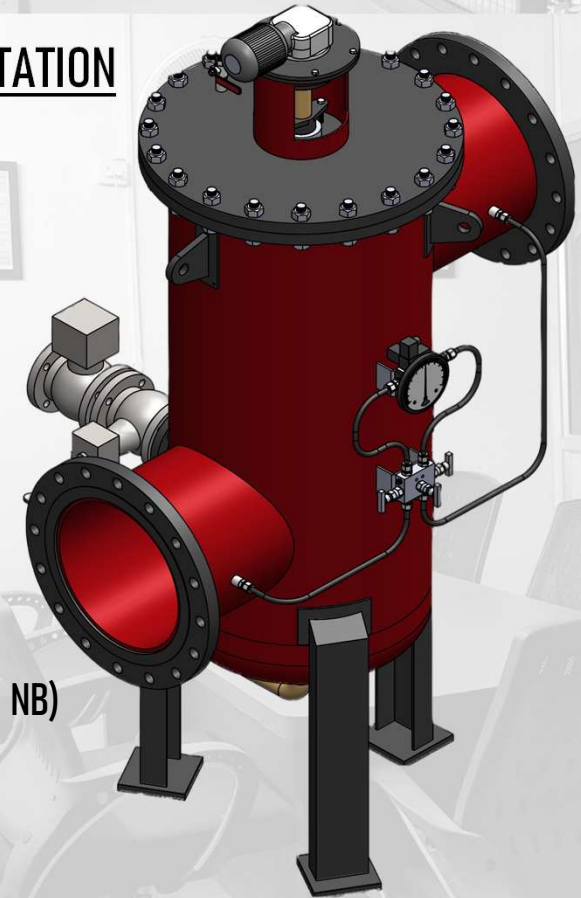

WATER SYSTEMS BY BCPL



Buchiya

... Serves need of all type of industries



KOPILI HEP (200MW), (ASSAM)

CYCLONE SEPERATOR

INLET/ OUTLET - 8" (200 NB)

Sr.No.	Item	Details
1	FLOW	3300 LPM
2	FILTRATION	75μ



WATER SYSTEMS BY BCPL



Buchiya

... Serves need of all type of industries

KIRU HEP (624 MW), JAMMU & KASHMIR

Sr.No.	Item	Details
1	FLOW	207lpm
2	FILTRATION	50 μ
3	DESIGN PRESSURE	10 BAR

3D REPRESENTATION

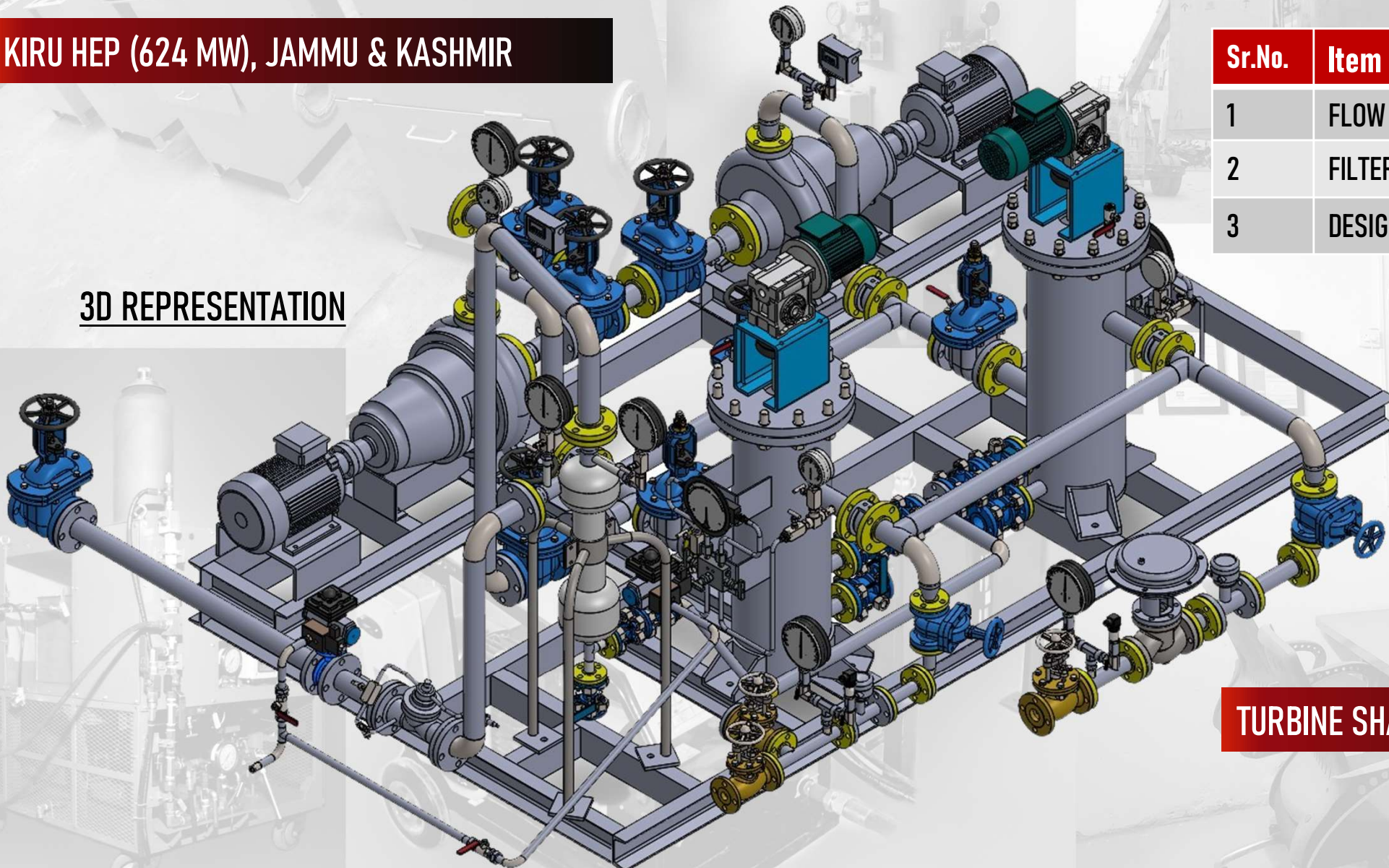

TURBINE SHAFT SEAL CONTROL PANEL

WATER SYSTEMS BY BCPL



Buchiya

... Serves need of all type of industries

KIRU HEP (624 MW), JAMMU & KASHMIR

Sr.No.	Item	Details
1	FLOW	690lpm
2	FILTRATION	50 μ
3	DESIGN PRESSURE	10 BAR

3D REPRESENTATION

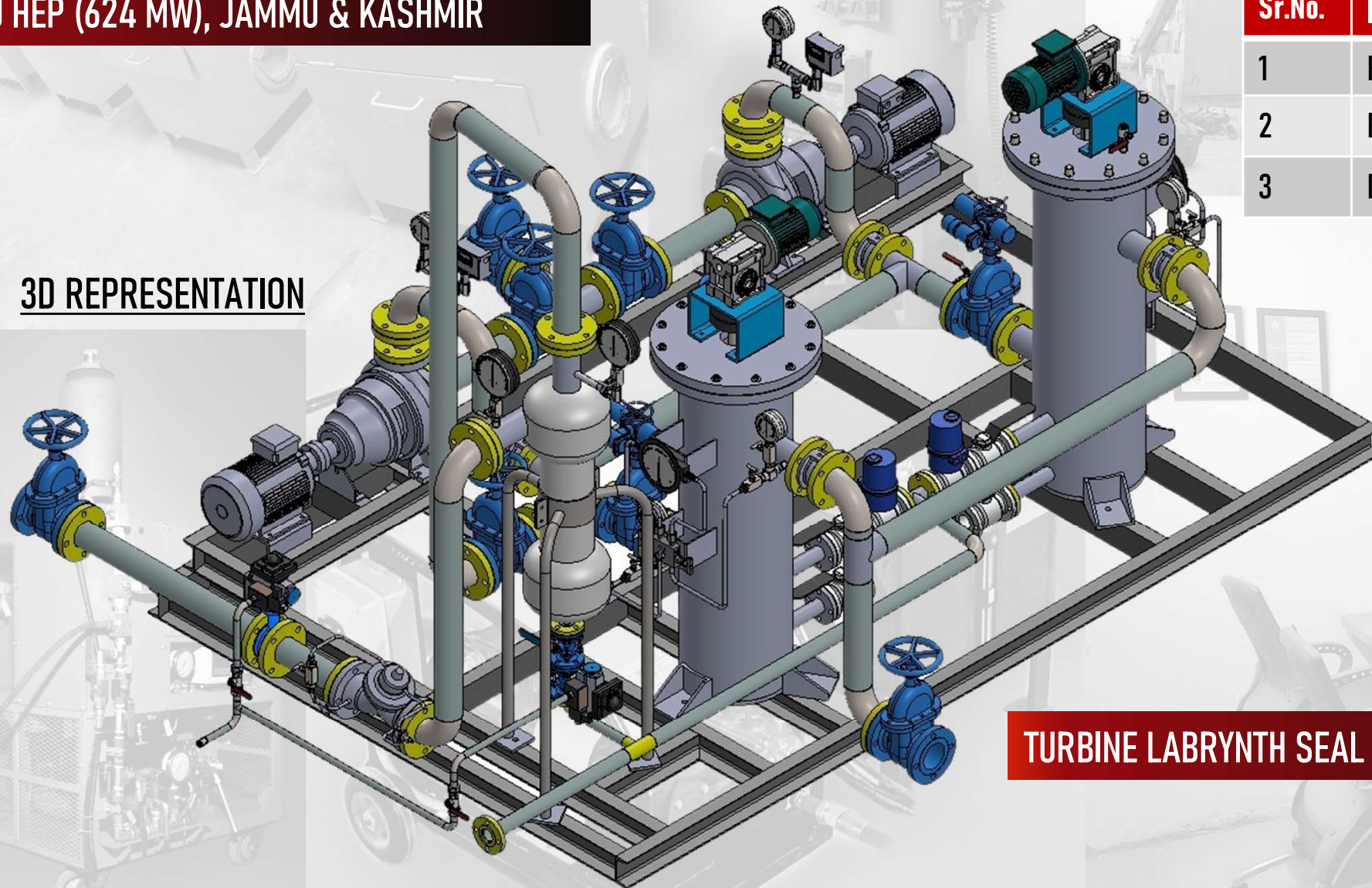

TURBINE LABRYNTH SEAL COOLING WATER SUPPLY PANEL

WATER SYSTEMS BY BCPL



Buchiya

... Serves need of all type of industries

PINNAPURAM PSP (600 MW), ANDHRA PRADESH

HIGH PRESSURE PUMPS



Sr.No.	Item	Details
1	FLOW	220 Lpm
3	DESIGN PRESSURE	7.5 Bar

3D REPRESENTATION

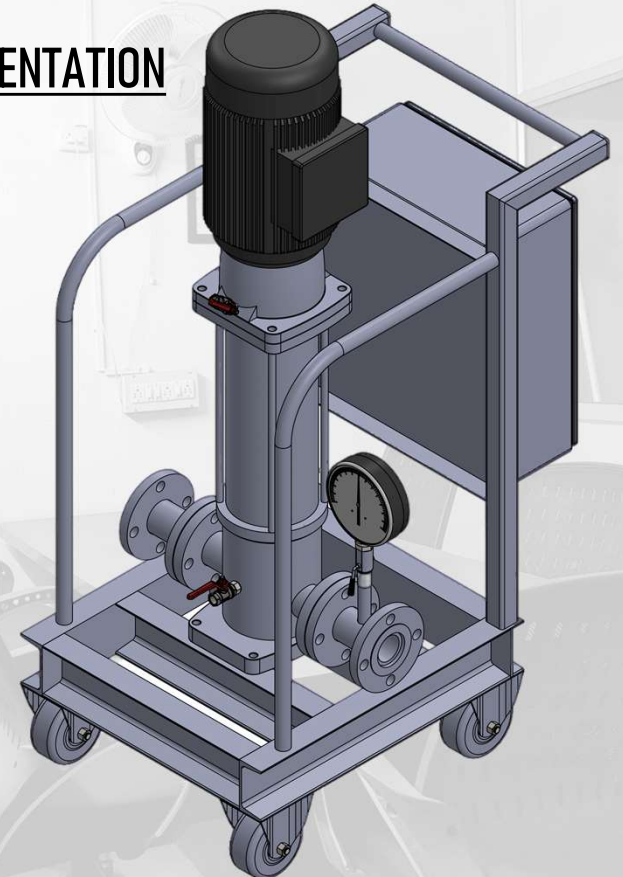

WATER SYSTEMS BY BCPL



Buchiya

... Serves need of all type of industries

UPPER TAMA KOSHI (465 MW), NEPAL

HIGH PRESSURE PUMPS

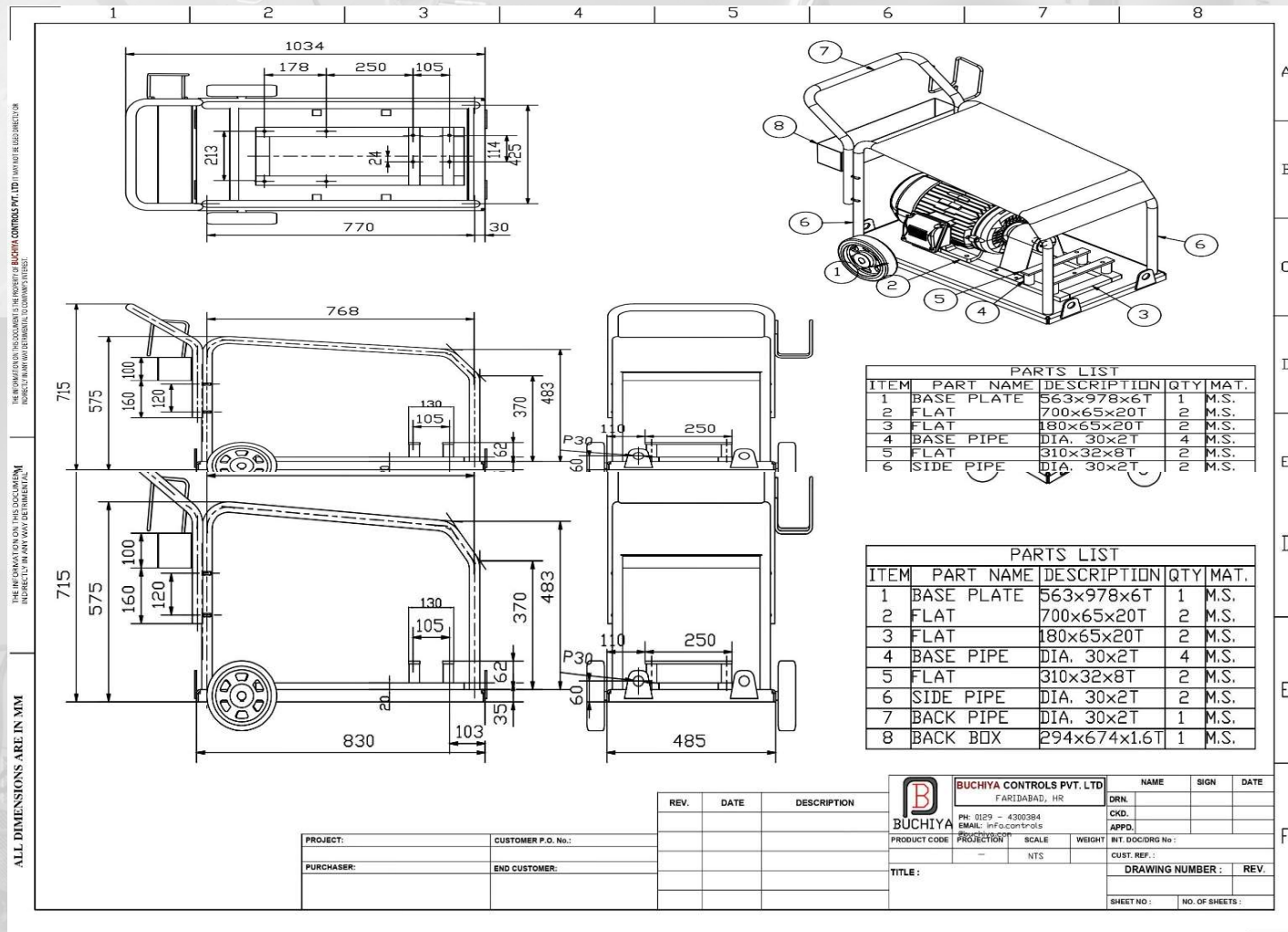

Sr.No.	Item	Details
1	TANK CAPACITY	100 Ltrs.
2	MOTOR / PUMP	10 H.P / 30 LPM @ 120 BAR



ALL DIMENSIONS ARE IN MM

THE INFORMATION CONTAINED IN THIS DOCUMENT IS THE PROPERTY OF BUCHIYA CONTROLS PVT. LTD. AND MAY BE UNCLASSIFIED OR DECLASSIFIED AT ANY TIME WITHOUT NOTICE.

BUCHIYA CONTROLS PVT. LTD. FARIDABAD, HR

REV.	DATE	DESCRIPTION	NAME	SIGN	DATE

BUCHIYA CONTROLS PVT. LTD.
 FARIDABAD, HR
 PH: 0129 - 4300384
 EMAIL: info@buchiya.com

PROJECT CODE: _____ SCALE: _____ WEIGHT: _____ INT. DOC/DRG No: _____
 TITLE: _____ CUST. REF.: _____
 DRAWING NUMBER: _____ REV: _____
 SHEET NO: _____ NO. OF SHEETS: _____

WATER SYSTEMS BY BCPL



Buchiya

... Serves need of all type of industries

SHONGTANG KARCHHAM (430 MW), HIMACHAL PRADESH

MIV SEAL OPERATING SYSTEM

COMMON
FOR
3 UNITS

S.No.	Item	Details
1	TANK CAPACITY	100 Ltrs.
2	MOTORS/PUMPS	3 H.P AC & DC/ 10 LPM @70 BAR

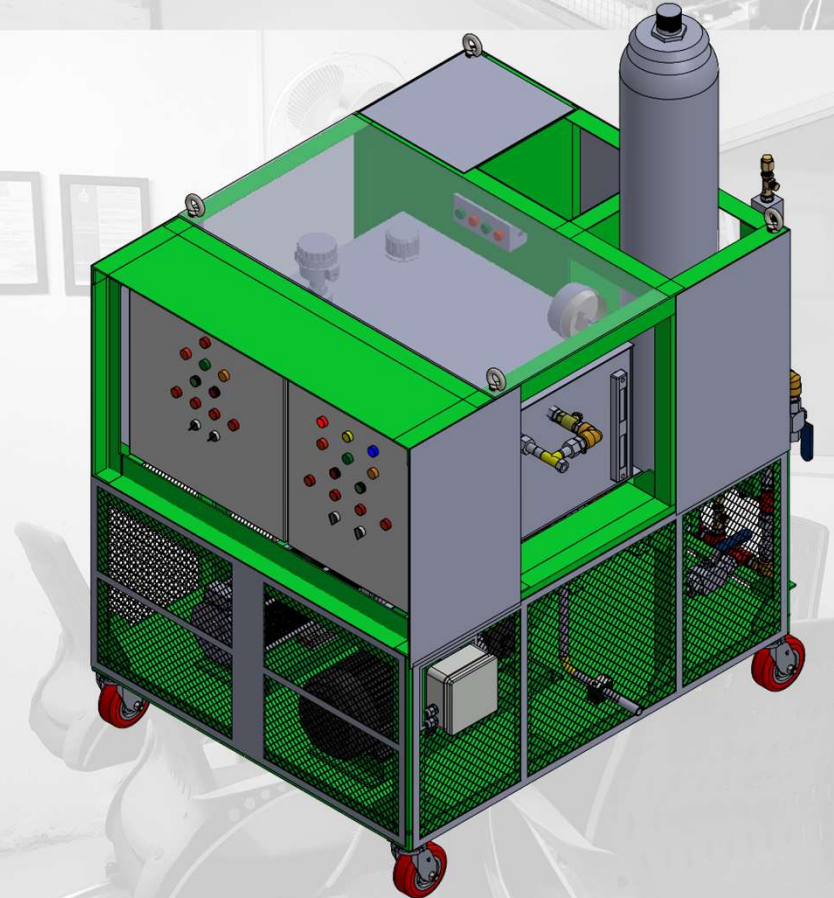

WATER SYSTEMS BY BCPL



Buchiya

... Serves need of all type of industries

IRUTTUKANAM SHP (3MW), KERALA

COOLING WATER SKID

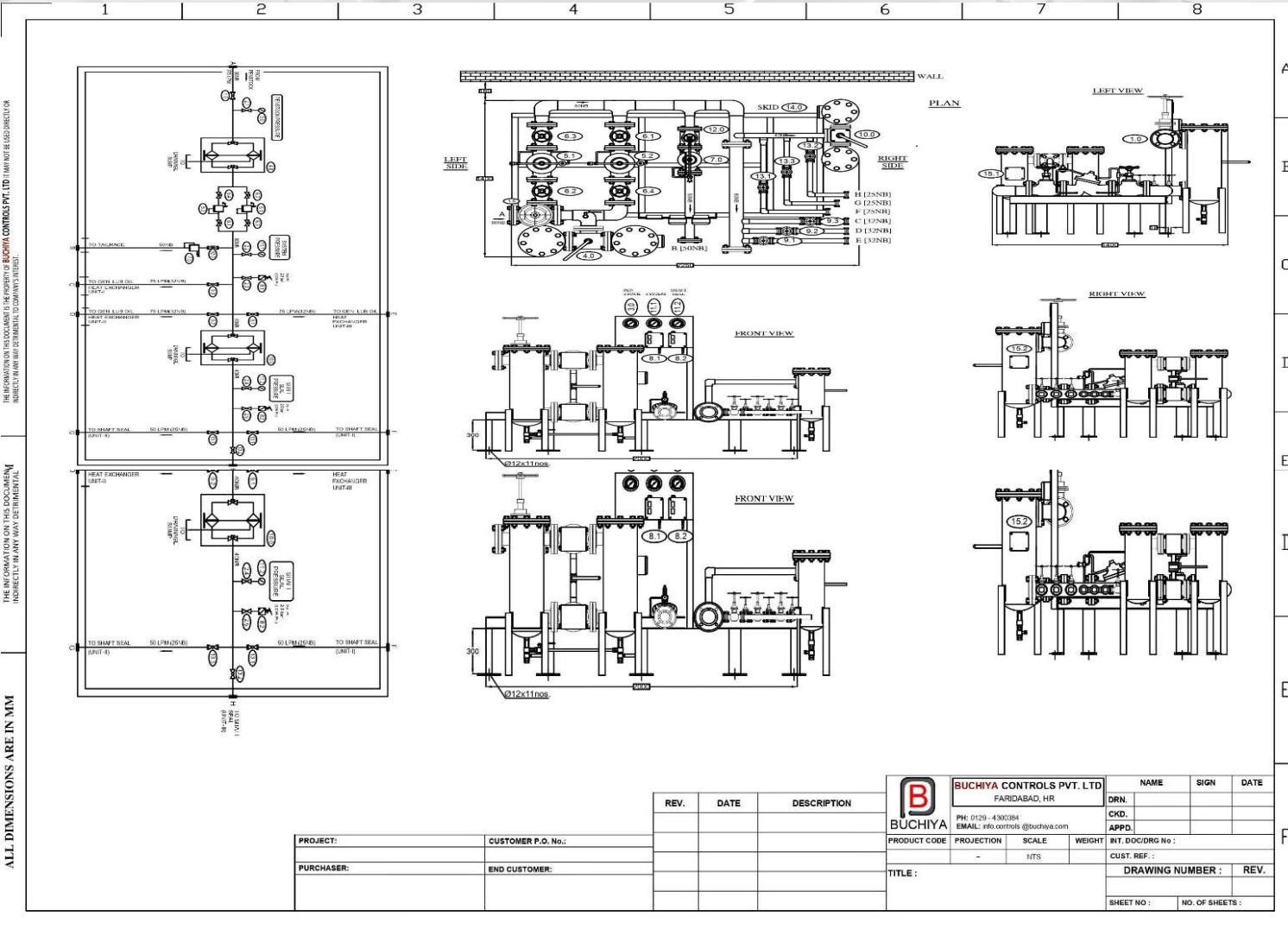

REV.	DATE	DESCRIPTION	NAME	SIGN	DATE

	BUCHIYA CONTROLS PVT. LTD FARIDABAD, HR			DRN.		
	PH: 0120 - 4300384 EMAIL: info.controls@buchiya.com			CKD.		
PRODUCT CODE	PROJECTION	SCALE	WEIGHT	INT. DOC/DRG No :	CUST. REF. :	
TITLE :	-	HTS			DRAWING NUMBER :	REV.
					SHEET NO :	NO. OF SHEETS :

PROJECT:	CUSTOMER P.O. No.:
PURCHASER:	END CUSTOMER:



Buchiya

... Serves need of all type of industries

THANK YOU

